

The Diffiety Institute Preprint Series

Preprint DIPS-11/98

December 15, 1998

Jumping oscillator

by

F. Pugliese, A. M. Vinogradov

Available via INTERNET:

<http://ecfor.rssi.ru/~diffiety/>

<http://www.botik.ru/~diffiety/>

anonymous FTP:

<ftp://ecfor.rssi.ru/general/pub/diffiety>

<ftp://www.botik.ru/~diffiety/preprints>

The Diffiety Institute

Polevaya 6-45, Pereslavl-Zalessky, 152140 Russia.

Jumping oscillator

F. Pugliese, A. M. Vinogradov

ABSTRACT. It is shown that a lagrangian system whose Legendre transformation degenerates along a hypersurface behaves in a strange manner by jumping from time to time without any "visible cause". In such a jump the system changes instantaneously its coordinates as well as its momenta. The mathematical dscription of the phenomenon is based on the theory of impact, refraction and reflection developed by one of the authors and the observation that a hamiltonian vector field, understood as a relative one, can be associated with any lagrangian, degenerated or not. Necessary elements of the general theory of such systems are reported and a detailed description of a post-relativistic oscillator showing such a behaviour is given.

CONTENTS

1. Introduction.	1
2. Hamiltonian Theory of Impact: the Transition Principle.	3
3. Lagrangians with Singular Hypersurfaces.	7
3.1. Relative vector fields	7
3.2. Singular Lagrangians and Relative Hamiltonian Theory of Impact and Refraction	8
4. Relativistic Oscillator	12
4.1. Relativistic Oscillator	12
4.2. Singular hypersurface of relativistic oscillator	13
4.3. Characteristic curves on S	16
4.4. Phase trajectories of the oscillator.	21
References	26

1. INTRODUCTION.

In Lagrangian mechanics two, in a sense, extremal situations were widely studied. One of them, classical, corresponds to systems with nowhere degenerated Legendre map. In this situation the Legendre map identifies the Lagrangian dynamics with the corresponding Hamiltonian one. On the contrary, in the second case the Legendre transformation is supposed to be everywhere degenerated (and of constant

Partially supported by the italian Ministero dell'Università e della Ricerca Scientifica e Tecnologica.

rank). Such a situation is common in gauge theories and by this reason was studied in several works, starting with the pioneering paper by Dirac [1]. But in a generic, in the sense of singularity theory, situation the Legendre map \mathcal{L} is almost everywhere non-degenerated except a critical hypersurface S . Since \mathcal{L} maps the tangent bundle $T(M)$ of the configuration space M of the system in question to the cotangent bundle $T^*(M)$, which both have the same dimension, the most generic singularities of \mathcal{L} are just folding points (see, for instance, [3]). In such a case S subdivides $T(M)$ or a suitable domain of it into a number of regular regions, inside each of which the dynamics admits the standard description either in Lagrangian or in Hamiltonian form. But what happens when a trajectory reaches the singular hypersurface S ? In this paper we show that it jumps. More exactly, if its arrival point is of the fold type, i.e. a generic one, then the moving point in M at a certain instant disappears suddenly and at the same time reappears in one or more, generally, distant points to continue its smooth motion up to an eventual subsequent jump. It is worth to emphasize that collisions and impacts of any kind in mechanics as well as refractions and reflections in geometrical optics in the context of the hamiltonian approach are phenomena of the same mathematical nature. In this case the "jumping" quantity is the velocity, but not the space-time coordinates (see [8], appendix 3).

In this paper, which is the first of a series planned to be written in this connection, we present the general mathematical background and then illustrate it with an example of a certain physical flavour, a relativistic oscillator in the post-Galilean approximation. Our approach is a fusion of two simple but, it seems, important observations.. The first of them is that the hamiltonian vector field can be associated naturally with any lagrangian, independently of the fact whether the corresponding Legendre map is degenerated or not. This field, however, is a relative one (see below) with respect to the Legendre map. The second observation is an analogy with the hamiltonian theory of impact as developed by one of the authors ([8], appendix 3).

It was not our goal here to discuss variational aspects of the problem. It will be done in a separate purely mathematical paper. We only remark that variational problems with non-regular lagrangians were already studied by K. Weierstrass and various authors later on (see, for instance, the Weierstrass-Erdmann theorem in [2]).

It seems that not too much attention was paid to physical systems the actions of which are not regular everywhere. We mention here recent works by G. Vilasi, I. Pavlotsky and their collaborators ([7], [4]), where some particular results concerning the post-Galilean oscillator and the Darwin two electrons-model were obtained. Our approach is, however, completely different and leads directly to a complete dynamical picture.

We hope that the forthcoming study of more realistic models will clarify the physical content of the proposed mechanism. At the moment its eventual applications look so attractive that it would be wiser to postpone speculations.

2. HAMILTONIAN THEORY OF IMPACT: THE TRANSITION PRINCIPLE.

Here we describe with the necessary details discontinuous hamiltonian systems, which will help us to understand the behaviour of dynamical systems described by singular lagrangians. Namely, the geometry that describes jumps of phase trajectories for such hamiltonian systems is the same as for lagrangian ones with singularities of fold type. In other words, the principle controlling these "jumps" in the pure hamiltonian case is quite transparent and shows what one has to do in the more complicated lagrangian situation.

Let (Φ, Ω) be the phase space of a dynamical system with $\Omega = \sum_i dp_i \wedge dq_i$ being a symplectic 2-form on Φ . Suppose then that Φ is divided by a hypersurface Γ into two closed domains Φ_+, Φ_- , having Γ as their common boundary, i.e. $\partial\Phi_+ = \Gamma = \partial\Phi_-$. Suppose also that the hamiltonian of the system is smooth on Φ_{\pm} . In other words, if $H_{\pm} = H|_{\Phi_{\pm}}$, then $H_{\pm} \in C^{\infty}(\Phi_{\pm})$. This, in particular, means that $H_{\pm}|_{\Gamma} \in C^{\infty}(\Gamma)$, but it is not supposed that $H_+|_{\Gamma}$ coincides with $H_-|_{\Gamma}$. So H , and consequently the hamiltonian field X_H associated to it, is well defined on $\Phi \setminus \Gamma$ and is bi-valued on Γ .

As it is well known, the local coordinate expression of $X_{H_{\pm}}$ is

$$X_{H_{\pm}} = \sum_i \left(\frac{\partial H_{\pm}}{\partial p_i} \frac{\partial}{\partial q_i} - \frac{\partial H_{\pm}}{\partial q_i} \frac{\partial}{\partial p_i} \right) \quad ,$$

The corresponding canonical equations :

$$\dot{q}_i = \frac{\partial H_{\pm}}{\partial p_i} \quad , \quad \dot{p}_i = -\frac{\partial H_{\pm}}{\partial q_i} \quad ,$$

describe the motion of the system *inside* Φ_{\pm} . But when the phase trajectory arrives at Γ it must "decide" under control of which hamiltonian to proceed on. The *transition principle* ([8]) prescribes how this decision should be taken. Below we recall this "recipe".

First, remember that to each point $x \in \Gamma$ the *characteristic line* $l_x \subset T_x(\Phi)$ of Γ at x is associated ([8]). This one-dimensional subspace is the skew-orthogonal complement of the hyperplane $T_x(\Gamma) \subset T_x(\Phi)$ with respect to the bilinear, skew-symmetric, non-degenerate form Ω_x . In other words:

$$l_x = \{ \xi \in T_x(\Phi) \mid \Omega_x(\xi, \eta) = 0 \quad \forall \eta \in T_x(\Gamma) \} \quad .$$

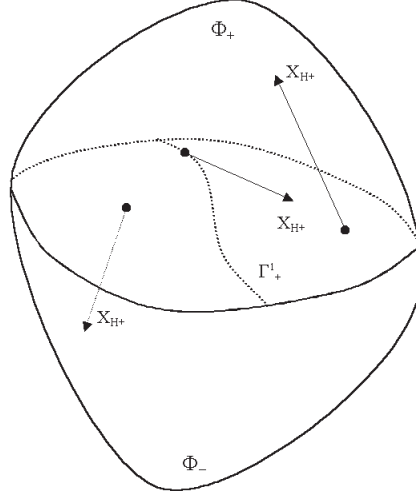

FIGURE 1. In- and out-points

Since $l_x \subset T_x(\Gamma)$, for any $x \in \Gamma$, this way we get a one-dimensional distribution $x \mapsto l_x$ on Γ , whose integral curves are called *characteristics* of Γ .

Example. Let S be a hypersurface in a manifold M , $\dim M = n$. Then, denoting by $\pi : T^*(M) \rightarrow M$ the canonical projection, we obtain the hypersurface $\Gamma = \pi^{-1}(S) \subset \Phi = T^*(M)$. Its characteristics are straight lines contained in the fibers $T_q^*(M)$, $q \in S$. In fact, let $q_n = 0$ be the equation of S in a certain local chart. Then this is also the equation of Γ in the corresponding chart (q, p) on Φ . By definition a vector $\xi \in T_x(\Phi)$, $x \in \Gamma$, is collinear to the characteristic direction at x iff covector $\Omega_x(\xi, \bullet)$ vanishes on $T_x(\Gamma)$, i.e. iff $\Omega_x(\xi, \bullet) = \lambda dq_n$ for some $\lambda \in \mathbf{R}$. It is easy to see that vector $\frac{\partial}{\partial p_n}|_x$ satisfies this condition. Hence characteristics are the integral curves of the vector field $\frac{\partial}{\partial p_n}$, i.e. straight lines.

Let $x \in \Gamma$. We say that x is a *+in-point* (resp., a *+out-point*) if $X_{H_+}|_x$ is directed toward Φ_+ (resp. Φ_-). Similarly, we say that x is a *-in-point* (resp., a *--out-point*) if $X_{H_-}|_x$ is directed toward Φ_- (resp. Φ_+) (see Fig. 1). In- and out-points of H_{\pm} are separated by a hypersurface $\Gamma_{\pm}^1 \subset \Gamma$ along which $X_{H_{\pm}}$ is tangent to Γ .

Suppose now that the phase trajectory, starting from a point inside of Φ_+ (resp. Φ_-), reaches a point $x \in \Gamma$ at an instant \bar{t} , and let E be the constant value of H_+ (resp. H_-) along the phase trajectory for $t \leq \bar{t}$. Denote by γ_x the characteristic curve of Γ passing through x , and by Σ_E^+ (resp. Σ_E^-) the hypersurface $\{H_+ = E\}$ (resp., $\{H_- = E\}$) of Φ_+ (resp., Φ_-). A point $y \in \gamma_x \cap \Sigma_E^+$ (resp. $\gamma_x \cap \Sigma_E^-$) is called *decisive* for x if it is an *+in-point* (resp. a *--in-point*). Now we can state the following

where $\|p\| = \sqrt{\sum_i p_i^2}$.

Let now M_+, M_- be two isotropic optical media with refraction indexes $n_+(q)$ and $n_-(q)$ respectively, separated by a surface S . Suppose that a ray starting from a point in M_+ reaches S at a point $\bar{q} \equiv (\bar{q}_1, \bar{q}_2, \bar{q}_3)$ with an impulse $\bar{p} \equiv (\bar{p}_1, \bar{p}_2, \bar{p}_3)$. The corresponding velocity is $\bar{v} = (\bar{v}_1, \bar{v}_2, \bar{v}_3)$, with $\bar{v}_i = \dot{q}_i = H_{p_i}(\bar{q}, \bar{p}) = V(\bar{q}) \bar{p}_i / \|\bar{p}\|$.

Pose: $M = \bar{M}_+ \cup \bar{M}_-, \Phi = T^*(M), \Phi_{\pm} = T^*(M_{\pm})$ and $\Gamma = \bigcup_{q \in S} T_q^*(M)$. So, the hypersurface Γ separates Φ_+ from Φ_- and the phase trajectory of the ray reaches Γ at a point $\bar{x} \equiv (\bar{q}, \bar{p})$. By the previous example the characteristic curve $\gamma_{\bar{x}}$ of S passing through x is a straight line contained in the fiber $T_{\bar{q}}^*(M)$. Let us choose coordinates (q_1, q_2, q_3) in such a way that S is tangent at \bar{q} to the hyperplane $\{q_3 = \bar{q}_3\}$ and the q_3 -axis is directed toward M_- . Then the characteristic direction at \bar{x} is parallel to $\frac{\partial}{\partial p_3}$ and $\gamma_{\bar{x}}$ is described by equations

$$(2) \quad \begin{aligned} q_i(t) &= \bar{q}_i \\ p_i(t) &= \bar{p}_i + \delta_{i3}t \quad , \quad t \in \mathbf{R}, \quad i = 1, 2, 3 \end{aligned}$$

If $E = H_+(\bar{q}, \bar{p})$, then, in view of (2) and (1), the intersection $\gamma_{\bar{x}} \cap \Sigma_E^+$ is composed of two points \bar{x} and x^* corresponding to values $\bar{t} = 0$ and $t^* = -2\bar{p}_3$, respectively. The point $x^* \equiv (\bar{q}, p^*)$ with $p^* = (\bar{p}_1, \bar{p}_2, -\bar{p}_3)$ is decisive for \bar{x} . In fact, by the choice of coordinates:

$$(X_{H_+})_{x^*}(q_3) = \frac{\partial H_+}{\partial p_3}(x^*) = -V_+(\bar{q}) \frac{\bar{p}_3}{\|\bar{p}\|} = -(X_{H_+})_{\bar{x}}(q_3) < 0 \quad ,$$

Therefore, the transition principle tells that the reflected ray does always exist, and starts from the same point $\bar{q} \in S$ in the direction $v^* = V(\bar{q}) p^* / \|p^*\|$ corresponding to p^* . Further, \bar{v}, v^* are coplanar with the normal to S at \bar{q} and form with it equal angles ϕ, ψ_+ , respectively. In fact

$$\cos \phi = \frac{|v_3^*|}{\|v^*\|} = \frac{|p_3^*|}{\|p^*\|} = \frac{|\bar{p}_3|}{\|\bar{p}\|} = \cos \psi_+ \quad ,$$

On the other hand the intersection $\gamma_{\bar{x}} \cap \Sigma_E^-$ corresponds to the values of t satisfying equation

$$(3) \quad t^2 + 2\bar{p}_3 t + (1 - \bar{n}^2) \|\bar{p}^2\| = 0 \quad ,$$

with $\bar{n} = n_-(\bar{q})/n_+(\bar{q})$. Equation (3) admits real solutions iff $\left(\frac{\bar{p}_3}{\|\bar{p}\|}\right)^2 = \left(\frac{\bar{v}_3}{V_+}\right)^2 \geq 1 - \bar{n}^2$, i.e. iff

$$\sin \phi = \sqrt{1 - \frac{\bar{v}_3^2}{V_+(\bar{q})^2}} \leq \bar{n} \quad .$$

Therefore, for values of ϕ greater than $\arcsin \bar{n}$ there is no refraction ("total reflection"). If instead $\phi \leq \arcsin \bar{n}$ (or if $\bar{n} > 1$), then (3) has two real solutions, $t = -\bar{p}_3 \pm \tilde{p}_3$, with $\tilde{p}_3 = \|\bar{p}\| \sqrt{\left(\frac{\bar{p}_3}{\|\bar{p}\|} + \bar{n}^2 - 1\right)}$, to which correspond the two intersections $(\bar{q}, \bar{p}_1, \bar{p}_2, \tilde{p}_3)$, $(\bar{q}, \bar{p}_1, \bar{p}_2, -\tilde{p}_3)$. Of these, only the first one is decisive for \bar{x} (one can see it, as before, by considering the orientation of X_{H_-}). Therefore, for $0 \leq \phi \leq \arcsin \bar{n}$ the refracted ray does exist, and its (initial) direction $\tilde{p} = (\bar{p}_1, \bar{p}_2, \tilde{p}_3)$ is coplanar with the incident ray and the normal to S at \bar{q} , and forms with this an angle ψ_- such that (*Snellius' law*):

$$\frac{\sin \phi}{\sin \psi_-} = \frac{\sqrt{1 - \frac{\bar{p}_3^2}{\|\bar{p}\|^2}}}{\sqrt{1 - \frac{\tilde{p}_3^2}{\|\tilde{p}\|^2}}} = \bar{n}$$

3. LAGRANGIANS WITH SINGULAR HYPERSURFACES.

In this section the Hamiltonian theory of impact and refraction, as described in the previous section, is extended to the singular lagrangians. This will allow us, as it was already mentioned in the introduction, to describe discontinuities of the motion that occur when the phase point of the system reaches the singular surface. We start with recalling the concept of relative vector field.

3.1. Relative vector fields. Let M and N be differentiable manifolds, related one another by smooth mapping $F : M \rightarrow N$. An \mathbf{R} -linear operator $X : C^\infty(N) \rightarrow C^\infty(M)$ is called a *relative vector field* on N along F if it satisfies the Leibniz rule:

$$X(fg) = F^*(f)X(g) + F^*(g)X(f) \quad f, g \in C^\infty(N)$$

If $f \in C^\infty(M)$ and X is a relative vector field, then fX is also a such one. Therefore relative vector fields on N along F form a $C^\infty(M)$ -module. Denote it by $\mathcal{D}(N, M; F)$. An "absolute" vector field X on N can be considered as a relative one along the identity map id_N .

Geometrically, a relative vector field $X \in \mathcal{D}(N, M; F)$ can be thought as a map which associates to any point $a \in M$ a vector X_a tangent to N at the point $F(a)$. Namely

$$X_a(f) := [X(f)](a) \quad , \quad f \in C^\infty(N)$$

Conversely, to each differentiable map $\sigma : M \rightarrow T(N)$ such that $p_N \circ \sigma = F$, where $p_N : T(N) \rightarrow N$ is the canonical projection, one can associate the relative vector field X defined by:

$$[X(f)](a) := \sigma(a)(f) \quad , \quad a \in M, f \in C^\infty(N)$$

If $x = (x_1, \dots, x_m)$, $y = (y_1, \dots, y_n)$ are local coordinates on M and N respectively, the corresponding local expression of $X \in \mathcal{D}(N, M; F)$

is:

$$X = \sum_{i=1}^n X^i(x) (F^* \circ \frac{\partial}{\partial y_i}),$$

where functions $X^i(x)$ are the components of X_x with respect to the basis $\frac{\partial}{\partial y_1}|_{F(x)}, \dots, \frac{\partial}{\partial y_n}|_{F(x)}$ of $T_{F(x)}(N)$. Below we will use the simplified notation

$$(4) \quad X = \sum_{i=1}^n X^i(x) \frac{\partial}{\partial y_i} \quad ,$$

having in mind that the vector field (4) acts on a function $\phi(y) \in C^\infty(N)$ as follows:

$$X(\phi)(x_1, \dots, x_m) = \sum_i X_i(x) \frac{\partial \phi}{\partial y_i}(y_1(x), \dots, y_n(x)) \quad ,$$

with $y_i = y_i(x)$ being the coordinate expression of F .

For more details concerning relative vector fields, see [6].

3.2. Singular Lagrangians and Relative Hamiltonian Theory of Impact and Refraction. Let M , $\dim M = n$, be the configuration space of a dynamical system described by a lagrangian $L \in C^\infty(T(M))$, and let $\mathcal{L} : T(M) \rightarrow T^*(M)$ be the corresponding Legendre mapping. Recall that, in a fixed local chart (q_1, \dots, q_n) on M , \mathcal{L} is represented by equations:

$$(5) \quad \begin{aligned} q_i &= q_i \quad , \quad i = 1, \dots, n \\ p_i &= L_{v_i}(q, v) \quad , \quad i = 1, \dots, n \quad , \end{aligned}$$

where $(q, v), (q, p)$ are special coordinates on $T(M)$ and $T^*(M)$, respectively, associated with (q_1, \dots, q_n) .

Let S be the singular points locus of the Legendre map :

$$S := \{x \in T(M) \mid \text{rk } d_x \mathcal{L} < n\}$$

This hypersurface can be described as follows. The Jacobian matrix of \mathcal{L} at point (q, v) is:

$$(6) \quad d_{(q,v)} \mathcal{L} \equiv \left\| \begin{array}{cc} \mathbf{1} & \mathbf{0} \\ L_{vq} & L_{vv} \end{array} \right\|$$

where $L_{vq} = \left\| L_{v_i q_j} \right\|$ and $L_{vv} = \left\| L_{v_i v_j} \right\|$ is the hessian matrix . Since the determinant of (6) is $\mathcal{H} := \det L_{vv}$, the equation of S is:

$$\mathcal{H}(q, v) = 0$$

We will assume that S is a regular hypersurface of $T(M)$. This assumption implies that for any point $(q, v) \in S$, $d_{(q,v)} \mathcal{H}$ does not vanish.

According to the standard procedure, the motion of the system outside S can be described by Euler-Lagrange equations:

$$(7) \quad \begin{cases} \dot{q}_i = v_i \\ \frac{d}{dt}(L_{v_i}) - L_{q_i} = 0 \end{cases} ,$$

$i = 1, \dots, n$. Equations (7) can be rewritten in the normal form:

$$(8) \quad \dot{v}_i = f_i(q, v)$$

in a neighbourhood of any point $(q, v) \in T(M) \setminus S$. On the other hand, this is no longer possible if $(q, v) \in S$. Namely, accelerations are undetermined on S and velocities may have discontinuities.

Recall (see, for instance, [3]) that $x \in T(M)$ is a *fold point* of \mathcal{L} if

$$(9) \quad \text{Ker } d_x \mathcal{L} \cap T_x(S) = \{0\} \quad \forall x \in S$$

$$(10) \quad d_x \mathcal{H} \neq 0 \quad \forall x \in S$$

Below we restrict our analysis only to fold points, which for a generic \mathcal{L} form an open everywhere dense subset in S .

In the next section we will see that the lagrangian of the post-galilean oscillator exhibits also some irregular singularities, which can be studied as well.

For our purposes it is important to note that the hamiltonian vector field associated with a lagrangian exists even if the corresponding Legendre map possesses some singularities. But in such a case this hamiltonian field *becomes a relative one*. Namely, define the relative vector field $X_H^{rel} \in D(T^*(M), T(M); \mathcal{L})$ by:

$$(11) \quad X_H^{rel} \stackrel{def}{=} \sum_i v_i \frac{\partial}{\partial q_i} + \sum_i L_{q_i}(q, v) \frac{\partial}{\partial p_i}$$

If \mathcal{L} is (locally) regular, i.e. a (local) diffeomorphism, then

$$X_H = (\mathcal{L}^{-1})^* \circ X_H^{rel}$$

is the standard hamiltonian field associated with L . This is easily seen from the standard coordinate expression of a hamiltonian field:

$$X_H = \sum_i (H_{p_i} \frac{\partial}{\partial q_i} - H_{q_i} \frac{\partial}{\partial p_i})$$

In fact, in this case

$$(12) \quad H(q, p) = E(q, v(q, p)) \quad ,$$

where $v = v(q, p)$ is the inverse of the Legendre map and

$$E(q, v) \stackrel{def}{=} \sum_i v_i L_{v_i}(q, v) - L(q, v)$$

is the energy. Keeping in mind (5) one finds

$$\begin{aligned} H_{p_j} &= \sum_i (\delta_{ij} v_i + p_i \frac{\partial v_i}{\partial p_j}) - \sum_i L_{v_i} \frac{\partial v_i}{\partial p_j} = v_j \\ H_{q_j} &= \sum_i p_i \frac{\partial v_i}{\partial q_j} - L_{q_j} - \sum_i L_{v_i} \frac{\partial v_i}{\partial q_j} = -L_{q_j} \end{aligned}$$

Hence, the vector field Z_L corresponding to Euler-Lagrange equations for L is well-defined on $T(M) \setminus S$ and, locally,

$$Z_L = \sum_i \left(v_i \frac{\partial}{\partial q_i} + f_i(q, v) \frac{\partial}{\partial v_i} \right),$$

with f_i 's given by (8). If $U \subset T(M) \setminus S$ is such that $\mathcal{L}_U \stackrel{\text{def}}{=} \mathcal{L}|_U : U \rightarrow \mathcal{L}(U)$ is a diffeomorphism, then the image $X_U \in \mathcal{D}(\mathcal{L}(U))$ of $Z_L|_U$ with respect to \mathcal{L}_U is well defined:

$$X_U = (\mathcal{L}_U^{-1})^* \circ Z_L \circ \mathcal{L}_U^*$$

and, moreover, is a hamiltonian vector field (in $\mathcal{L}(U)$) corresponding to the Hamilton function $H_U = E \circ \mathcal{L}_U^{-1} \in C^\infty(\mathcal{L}(U))$. If U' is another regular domain for \mathcal{L} such that $\mathcal{L}(U') = \mathcal{L}(U)$, then, generally, $H_{U'} \neq H_U$ or, equivalently, $X_U \neq X_{U'}$ (in $\mathcal{L}(U)$). In other words, in $\mathcal{L}(U)$ a multi-valued hamiltonian field is well-defined. So, on the whole, a multi-valued hamiltonian field is defined and its various branches are matching one another along $\mathcal{L}(S)$.

Now we pass to describe the analogues of in- and out-points (see section 2) in the considered context. The following elementary facts from singularity theory (see, for instance, ([3])) are needed for this purpose. First, recall the notion of a submersion with folds. Let P, Q be two manifolds, with $\dim P = n \geq \dim Q = m$. The *first-order jet* $[F]_x^1$ of a map $F : P \rightarrow Q$ at a point $x \in P$ may be considered as a triple (x, y, p) , with $y = F(x)$ and $p : T_x(P) \rightarrow T_y(Q)$ being the differential of F at x . The manifold of all the first-order jets of maps from P to Q is denoted by $J^1(P, Q)$. The submanifold $S_1 \subset J^1(P, Q)$ is composed of all triples (x, y, p) such that $\text{rk } p = n - 1$. The map $j^1 F : P \rightarrow J^1(P, Q)$ sends a point $x \in P$ to $[F]_x^1$. F is called a *submersion with folds* if:

- 1) $j^1 F$ is transversal to S_1 ;
- 2) $\text{Ker } d_x F$ is transversal to $S_1(F) = (j^1 F)^{-1}(S_1)$, for every $x \in S_1(F)$.

It is easy to see that in the case $n = m$ condition 1) is equivalent to the fact that the jacobian of F has only simple zeroes along $S_1(F)$.

The local structure of a submersion with folds is described by the following

Theorem 3.1. *Let $F : P \rightarrow Q$ be a submersion with folds and let $\bar{x} \in S_1(F)$. Then there exist coordinates (x_1, \dots, x_n) on P and (y_1, \dots, y_m)*

on Q , centered at \bar{x} and $F(\bar{x})$ respectively, in terms of which F takes the form:

$$\begin{aligned} y_1 &= x_1 \\ &\vdots \\ y_{m-1} &= x_{m-1} \\ y_m &= x_m^2 \pm x_{m+1}^2 \pm \dots \pm x_n^2 \end{aligned}$$

◀ see [3] ▶.

In the case we are interested in, $P = T(M)$, $Q = T^*(M)$, $F = \mathcal{L}$, $\dim P = \dim Q = 2n$. Assumptions (9), (10) guarantee \mathcal{L} to be a submersion with folds. According to theorem 3.1, its normal form is:

$$(13) \quad \begin{aligned} y_1 &= x_1 \\ &\dots\dots\dots \\ y_{2n-1} &= x_{2n-1} \\ y_{2n} &= x_{2n}^2 \end{aligned}$$

It results easily from the above description and from (13) that the range of \mathcal{L} locally belongs to the half-space $y_{2n} \geq 0$. This allows us to extend the definition of in- and out-points and the corresponding transition principle to the lagrangian case. Namely, a point $x \in S$ is called an *in-point* if $X_H^{rel}|_x$ is directed toward the range of \mathcal{L} , $X_H^{rel}|_x (y_{2n}) > 0$, while it is called an *out-point* if $X_H^{rel}|_x$ is directed outside of it, $X_H^{rel}|_x (y_{2n}) < 0$.

Let us note that the pullback $\mathcal{L}^*(\Omega)$ of the canonical symplectic form on $T^*(M)$ along the Legendre map is degenerated on S and is of rank $2n - 2$ at any fold point. The restriction $\Omega_S \stackrel{def}{=} \mathcal{L}^*(\Omega)|_S$ continues to be of rank $2n - 2$ due to (9). This means that the kernel l_x of Ω_S at a fold point $x \in S$ is one-dimensional. This way one gets a one-dimensional distribution on S_{fold} . Characteristic curves are integral curves of it. Denote by γ_x the characteristic curve passing through $x \in S$.

Now it is clear how to extend the transition principle to the lagrangian case. Namely, calling decisive for $x \in S$ any in-point $y \in \gamma_x$ belonging to the same level Σ_E of energy of x , the principle can be stated as follows.

Transition Principle (lagrangian case). *When a phase point moving along Z_L reaches at an instant a point $x \in S$, it then continues its motion along all trajectories of Z_L issuing from points decisive for x . Moreover, the passage from x to a decisive point is instantaneous.*

Remark 1. Note that the transition principle implies that the energy does not change under an impact with S .

Remark 2. According to the principle there are in general as many possible phase trajectories after the impact with S at a point x as are the points decisive for x .

4. RELATIVISTIC OSCILLATOR

In this section the behaviour of a relativistic oscillator whose lagrangian possesses fold singularities is analysed on the base of Transition Principle. We have chosen this example to show the above theory in action mainly because of its relative simplicity: its phase trajectories and characteristics can be described analytically without difficulties. However, we will see that even in this simple case the behaviour of phase trajectories with respect to the singular surface is rather interesting, at least from a geometrical point of view.

By applying the transition principle to describe the discontinuities of motion of relativistic oscillator we discover a rather remarkable phenomenon. Namely, if the energy exceeds a certain level and at the same time the velocity is not too high, the oscillator starts jumping. In other words, after a smooth motion it instantaneously changes its position (as well as velocity). In the classical example of reflection and refraction of light, or elastic collision of bodies and particles, there is no discontinuity of position. It is worth noting that the "jumping" motions of the oscillator are in a good consistency with the smooth ones.

Finally we note that the relativistic oscillator possesses also singularities of non-fold type. These are very degenerated and the phase portrait in this region is rather curious.

4.1. Relativistic Oscillator. Recall that there were proposed various relativistic generalizations of the standard harmonic oscillator (see for instance [7]). Some of them possess singularities, while others not. Below we study the two-dimensional post-galilean oscillator of tensor rank 2 ([7]), possessing both fold and not fold type singularities:

$$(14) \quad L = L(r, x) = -mc^2 \left[\sqrt{1-x} + \left(\frac{r}{r_0}\right)^2 \left(1 + \frac{x}{2}\right) \right]$$

Here m, r_0 are the mass and the characteristic length of the oscillator respectively, linked by the relation $r_0 = \sqrt{\frac{m}{k}}c$ (with k being the elastic constant); r is the distance between the oscillating mass and the elastic force centre; $x = \frac{v^2}{c^2}$ is the square of oscillator velocity, measured with respect to the light velocity c . If we fix in the plane of motion a system of orthogonal coordinates (q_1, q_2) with the origin at the centre of the force, then obviously:

$$r = \sqrt{q_1^2 + q_2^2} \quad x = \frac{v_1^2 + v_2^2}{c^2}$$

Note that

$$(15) \quad 0 \leq x < 1 \quad ,$$

due to the fact that $v^2 < c^2$. Below we refer to $M = \mathbf{R}^2 = \{(q_1, q_2)\}$ as the configuration space. So the lagrangian (14) is defined in the

domain $\mathcal{U} \subset T(M) = \{(q, v)\} = \mathbf{R}^2 \times \mathbf{R}^2$, defined as:

$$\mathcal{U} = \{(q, v) \in T(M) \mid q \in M, \|v\| < c\}$$

However we will often not distinguish between \mathcal{U} and $T(M)$. A similar convention will be adopted also for the cotangent bundle $T^*(M)$.

Below we will systematically use in \mathcal{U} the system of coordinates (r, ϕ, x, θ) (or equivalently (r, ϕ, x, u) , with $u = \theta - \phi$), where ϕ and ϑ are the angle between q_1 -axis and $\mathbf{r} \equiv (q_1, q_2)$, and the angle between \mathbf{r} and the velocity vector $\mathbf{v} \equiv (v_1, v_2)$, respectively.

To simplify general considerations concerning lagrangian (14) it is convenient to work with a generic lagrangian of the form

$$(16) \quad L = L(r, x)$$

The energy function

$$(17) \quad E = v_1 L_{v_1} + v_2 L_{v_2} - L$$

takes the following form for lagrangian (16):

$$(18) \quad E(r, x) = 2x L_x - L$$

which in the case of oscillator (14) becomes:

$$E(r, x) = mc^2 \left[\frac{1}{\sqrt{1-x}} + \left(\frac{r}{r_0} \right)^2 \left(1 - \frac{x}{2} \right) \right]$$

Lagrangian (16) admits also another integral of motion, namely the *angular momentum*:

$$(19) \quad I(r, x, u) = \frac{2}{c^2} L_x(r, x) (q_1 v_2 - q_2 v_1) = \frac{2}{c} r \sqrt{x} L_x(r, x) \sin u$$

For lagrangian (14) it is specified as:

$$I(r, x, u) = mcr \sqrt{x} \left[\frac{1}{\sqrt{1-x}} - \left(\frac{r}{r_0} \right)^2 \right] \sin u$$

The integral I corresponds, via Noether's theorem, to the infinitesimal symmetry :

$$X = -q_2 \frac{\partial}{\partial q_1} + q_1 \frac{\partial}{\partial q_2} = \frac{\partial}{\partial \phi} \quad ,$$

of lagrangian (16).

4.2. Singular hypersurface of relativistic oscillator. The Legendre map \mathcal{L} associated with lagrangian (16) is given by:

$$(20) \quad \begin{aligned} q_i &= q_i \\ p_i &= L_{v_i} = \frac{2}{c^2} L_x v_i \quad , \quad i = 1, 2 \end{aligned}$$

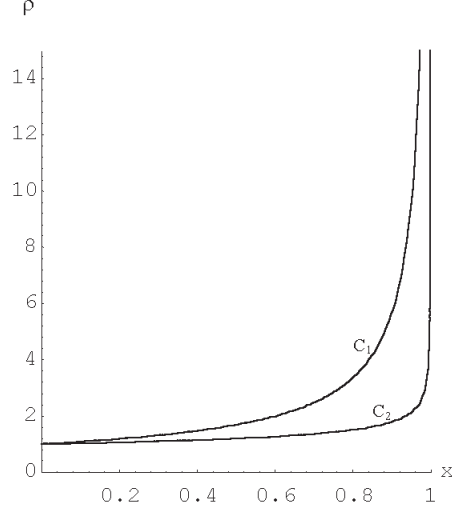
FIGURE 3. Singular surface ($r = r/r_0$)

The corresponding jacobian matrix (6) in terms of standard coordinates (q, v) and (q, p) in $T(M)$ and $T^*(M)$, respectively, has the entries:

$$L_{v_i q_j} = \frac{2}{c^2} \frac{L_{xr}}{r} v_i q_j \quad , \quad L_{v_i v_j} = \frac{2}{c^2} L_x \delta_{ij} + \frac{4}{c^4} L_{xx} v_i v_j \quad i, j = 1, 2$$

So, the corresponding Hessian is

$$\mathcal{H}(q, v) = L_{v_1 v_1} L_{v_2 v_2} - L_{v_1 v_2}^2 = \frac{4}{c^4} L_x (L_x + 2x L_{xx}) = \mathcal{H}(r, x)$$

It is easy to see that:

$$(21) \quad L_x + 2x L_{xx} = E_x \quad ,$$

and, therefore,

$$\mathcal{H}(r, x) = \frac{4}{c^4} L_x E_x$$

Hence,

$$E_x L_x = 0$$

is the equation of the singular hypersurface S . In other words

$$S = S_1 \cup S_2 \quad ,$$

with $S_1 = \{E_x = 0\}$, $S_2 = \{L_x = 0\}$. Each of these hypersurfaces is fibered in tori (ϕ, θ) , some of which may reduce to circles or to a point, depending on L . The bases of these "fibrations" are curves C_1, C_2 in (x, r) -plane, given by equations $E_x(r, x) = 0$ and $L_x(r, x) = 0$, respectively. These curves for the oscillator (14) are shown in Fig 3. In this case the intersection $\gamma = S_1 \cap S_2$ is the circle $\{r = r_0, x = 0\}$

included in the null section $M \subset T(M)$. γ is the locus $\text{Sing } S$ of singular points of S . This follows easily from the relations

$$\begin{aligned}\mathcal{H}_{q_i} &= \frac{q_i}{r} \mathcal{H}_r = \frac{q_i}{r} (L_{xr} E_x + L_x E_{xr}) \\ \mathcal{H}_{v_i} &= 2 \frac{v_i}{c^2} \mathcal{H}_x = 2 \frac{v_i}{c^2} (L_{xx} E_x + L_x E_{xx}) \quad ,\end{aligned}$$

and from the fact that $S_1 \setminus \gamma$ and $S_2 \setminus \gamma$ are regular.

Now we pass to describe how the kernel of the Legendre map behaves along the singular hypersurface S . It follows from (6) that a vector $\xi = \sum_{i=1}^2 \left(a_i \frac{\partial}{\partial q_i} + b_i \frac{\partial}{\partial v_i} \right)$ belongs to the kernel of $d\mathcal{L}$ iff

$$(22) \quad a_1 = a_2 = 0 \quad , \quad L_{vv} \begin{pmatrix} b_1 \\ b_2 \end{pmatrix} = \begin{pmatrix} 0 \\ 0 \end{pmatrix}$$

In full details, the second of conditions (22) looks as:

$$(23) \quad \begin{aligned} \left(L_x + \frac{2}{c^2} L_{xx} v_1^2 \right) b_1 + \frac{2}{c^2} L_{xx} v_1 v_2 b_2 &= 0 \\ \frac{2}{c^2} L_{xx} v_1 v_2 b_1 + \left(L_x + \frac{2}{c^2} L_{xx} v_2^2 \right) b_2 &= 0 \end{aligned}$$

By construction these equations are linearly dependent at any point of S .

For a point $(q, v) \in S_2 \setminus S_1$ there are two possibilities: $L_{xx}(q, v) = 0$ or $L_{xx}(q, v) \neq 0$. In the first case the system becomes trivial and $\text{Ker } d_{(q,v)} \mathcal{L}$ is two-dimensional. This never happens for the oscillator (14). In the second case system (23) reduces to the linear equation:

$$v_1 b_1 + v_2 b_2 = 0$$

Except for the points $(v_1 = v_2 = 0)$, $\text{Ker } d_{(q,v)} \mathcal{L}$ is one-dimensional. It is generated by the vector $v_2 \frac{\partial}{\partial v_1} - v_1 \frac{\partial}{\partial v_2}$, which coincides with $-\frac{\partial}{\partial u}$ in coordinates (r, ϕ, x, u) . This shows that in both cases $\text{Ker } d_{(q,v)} \mathcal{L}$ is tangent to S_2 . So fold type singularities do not belong to S_2 and $\dim \mathcal{L}(S_2) < 3$. For the oscillator (14) $\mathcal{L}(S_2)$ is 2-dimensional and coincides with the null section of $T^*(M)$.

Now we go to describe fold points belonging to $S_1 \setminus S_2$. These form an open domain $S_1^{\text{fold}} \subset S_1$ everywhere dense in S_1 .

If $(q, v) \in S_1 \setminus S_2$, it follows from (21) that $L_x = -2x L_{xx}$, hence (23)₂ becomes

$$v_2 b_1 - v_1 b_2 = 0$$

Therefore we have that $\text{Ker } d_{(q,v)} \mathcal{L} = \text{Span} \left(v_1 \frac{\partial}{\partial v_1} + v_2 \frac{\partial}{\partial v_2} \right) = \text{Span} \left(\frac{\partial}{\partial x} \right)$ on $S_1 \setminus S_2$.

Thus, singularities of \mathcal{L} along S_1 are of a substantially different nature from those along S_2 . Namely, the kernel of $d\mathcal{L}$ is *transversal* to $S_1 \setminus S_2$ (due to the fact that $E_{xx} \neq 0$ on it) and is *tangent* to S_2 , since $\frac{\partial L_x}{\partial u} = 0$ on it. Hence, $\dim \mathcal{L}(S_2) < 3$ and the transition principle

can not be applied to S_2 . In the next section we shall see that even characteristic directions are undetermined on S_2 .

4.3. Characteristic curves on S . To simplify computations we will make use of coordinates (r, x, ϕ, ϑ) (or, equivalently, (r, x, u, ϕ)). Let

$$\rho = \sum_i p_i dq_i$$

be the universal 1-form on $T^*(M)$ ([8]). Then

$$(24) \quad \mathcal{L}^*(\rho) = L_{v_1} dq_1 + L_{v_2} dq_2 = \frac{2}{c} \sqrt{x} L_x(r, x) (\cos u dr + r \sin u d\phi)$$

It follows from (24) that $\mathcal{L}^*(\rho) |_{S_2} = 0$. Hence

$$\mathcal{L}^*(\Omega) |_{S_2} = 0$$

Therefore, $\mathcal{L}(S_2)$ is a lagrangian submanifold in $T^*(M)$ (with possible singularities) and characteristic directions on S_2 are undetermined.

Now we pass to describe characteristics on S_1^{fold} . Since $grad \mathcal{H} \neq 0$ on it, the equation $E_x(r, x) = 0$ of S_1 can be solved with respect to one of the variables, say r :

$$r = r_1(x) \quad \text{on } S_1^{fold}$$

In the case of the oscillator (14):

$$r_1(x) = \frac{r_0}{(1-x)^{\frac{3}{4}}}$$

So (x, u, ϕ) can be taken as local coordinates on S_1^{fold} . Then from (24) we get:

$$\mathcal{L}^*(\rho) |_{S_1} = \frac{2}{c} \sqrt{x} L_x(r_1(x), x) \left[r_1'(x) \cos u dx + r_1(x) \sin u d\phi \right],$$

so that

$$(25) \quad \mathcal{L}^*(\Omega) |_{S_1} = d\mathcal{L}^*(\rho) |_{S_1} = \frac{2}{c} [\alpha(x, u) dx \wedge du + \beta(x, u) dx \wedge d\phi + \gamma(x, u) du \wedge d\phi],$$

with

$$\begin{aligned} \alpha(x, u) &= \sqrt{x} L_x(r_1(x), x) r_1'(x) \sin u \\ \beta(x, u) &= \frac{d}{dx} [r_1(x) \sqrt{x} L_x(r_1(x), x)] \sin u \\ \gamma(x, u) &= r_1(x) \sqrt{x} L_x(r_1(x), x) \cos u \end{aligned}$$

Characteristic directions on S_1 are described by a characteristic vector field $X \in \mathcal{D}(S_1)$, i.e. such that

$$(26) \quad \mathcal{L}^*(\Omega) |_{S_1} (X, \bullet) = 0$$

If

$$X = a \frac{\partial}{\partial x} + b \frac{\partial}{\partial u} + c \frac{\partial}{\partial \phi} \quad , \quad a, b, c \in C^\infty(S_1) \quad ,$$

then (26) is equivalent, in view of (25), to

$$\begin{pmatrix} 0 & -\alpha & -\beta \\ \alpha & 0 & -\gamma \\ \beta & \gamma & 0 \end{pmatrix} \begin{pmatrix} a \\ b \\ c \end{pmatrix} = \begin{pmatrix} 0 \\ 0 \\ 0 \end{pmatrix}$$

This system is of rank 2 on S_1^{fold} , and its fundamental solution is

$$(a, b, c) = (\gamma, -\beta, \alpha)$$

Therefore,

$$\begin{aligned} X &= \gamma \frac{\partial}{\partial x} - \beta \frac{\partial}{\partial u} + \alpha \frac{\partial}{\partial \phi} = \\ & q(x) \cos u \frac{\partial}{\partial x} - q'(x) \sin u \frac{\partial}{\partial u} + r_1'(x) \sqrt{x} L_x(r_1(x), x) \sin u \frac{\partial}{\partial \phi} \quad , \end{aligned}$$

with $q(x) = r_1(x) \sqrt{x} L_x(r_1(x), x)$ and characteristic curves are solutions of the system:

$$(27) \quad \begin{aligned} \dot{x} &= q(x) \cos u \\ \dot{u} &= -q'(x) \sin u \\ \dot{\phi} &= q(x) \frac{r_1'(x)}{r_1(x)} \sin u \end{aligned}$$

Integration of system (27) is reduced, obviously, to its subsystem (27)_{1,2}, whose solutions are to be described in the rectangle $[0, 1] \times [-\pi, \pi]$ due to the ciclicity of u .

It follows from (27)_{1,2} that

$$(28) \quad \frac{du}{dx} = -\frac{q'(x)}{q(x)} \tan u \quad ,$$

and, consequently,

$$\begin{aligned} \int \frac{du}{\tan u} &= \ln |\sin u| = - \int \frac{q'(x)}{q(x)} dx = - \int \frac{dq}{q} = - \ln |q(x)| + const. \\ &= \ln \frac{c}{|q(x)|} \quad , \quad c > 0 \end{aligned}$$

Hence the general integral of (28) is

$$(29) \quad \sin u = \frac{a}{q(x)} \quad , \quad a \in \mathbf{R}$$

For the oscillator (14) it is specified as:

$$\sin u = -\frac{2a}{mc^2 r_0} \frac{(1-x)^{\frac{9}{4}}}{x^{\frac{3}{2}}}$$

FIGURE 4. Characteristic curves on S_1 

FIGURE 5. Intersection between a characteristic curve and the energy level surface

Let us remark that $q(x) \sin u = \frac{c}{2} I |_{S_1}$. So (29) shows that I is constant along characteristic curves of S_1 . Therefore, by the transition principle, angular momentum (as well as energy) *does not change after the impact with S_1* .

The curves (29), denote them by γ_a , for the oscillator are shown in Fig. 4. Since the variable u is cyclic mod 2π and γ_a and γ_{-a} are symmetric with respect to the x -axis we can limit ourselves to dealing with the curves in the rectangle $(x, u) \in [0, 1] \times [0, \pi]$.

Let $\bar{P} \equiv (\bar{x}, \bar{u}, \bar{\phi}) \in S_1$ and let $\gamma_{\bar{a}}$ be the characteristic passing through \bar{P} , $\bar{E} = E(\bar{P})$. The intersection between the energy level surface $\Sigma_{\bar{E}}$ and S_1 is the torus $T_{\bar{E}} = \{r = r_1(\bar{x}), x = \bar{x}\}$. The projection of $T_{\bar{E}}$ onto the (x, u) -plane is the line $x = \bar{x}$. For the oscillator (14) this is shown, together with the projection of $\gamma_{\bar{a}}$, in Fig. 5. Therefore,

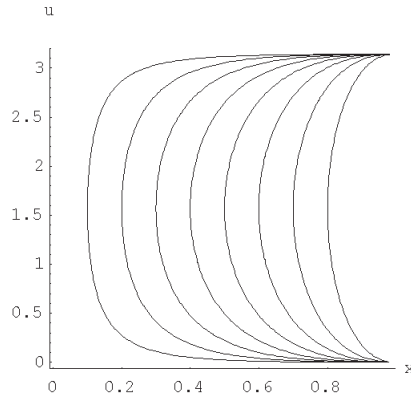
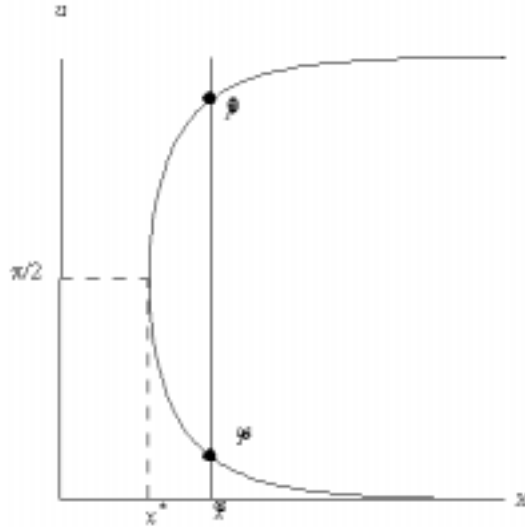
assuming $\bar{u} \in [0, \pi]$, $\gamma_{\bar{a}}$ intersects $T_{\bar{E}}$ at \bar{P} and at $\tilde{P} \equiv (\bar{x}, \pi - \bar{u}, \tilde{\phi})$. In order to determine ϕ notice that

$$(30) \quad \frac{d\phi}{dx} = \frac{r_1'(x)}{r_1(x)} \tan u = \pm \frac{r_1'(x)}{r_1(x)} \frac{\sin u}{\sqrt{1 - \sin^2 u}} = \pm |\bar{a}| \frac{r_1'(x)}{r_1(x) \sqrt{q^2(x) - \bar{a}^2}} \quad ,$$

as it results directly from (27)_{1,2} and (29). In (30) the choice of " + " (resp. " - ") corresponds to $u \in [0, \frac{\pi}{2}[$ (resp. $u \in]\frac{\pi}{2}, \pi]$). Hence, the possible position jump is described by the following formula:

$$(31) \quad \tilde{\phi} - \bar{\phi} = \Delta\phi(\bar{x}, \bar{u}) = \pm 2 |\bar{a}| \int_{x^*}^{\bar{x}} \frac{r_1'(x)}{r_1(x) \sqrt{q^2(x) - \bar{a}^2}} dx \quad ,$$

where x^* (see Fig. 5) is the root of the equation

$$(32) \quad |q(x)| = |\bar{a}| \quad ,$$

and the sign + (resp. -) corresponds to $\bar{u} \in [\pi/2, \pi]$ (resp. $\bar{u} \in [0, \pi/2]$). In the case of the oscillator equation (32) becomes

$$x^2 = \left(\frac{2|\bar{a}|}{mc^2 r_0} \right)^{4/3} (1-x)^3 \quad ,$$

which has only one root x^* in the interval $[0, 1[$. Relation (30) remains valid also for $\bar{u} \in [-\pi, 0]$. In this case the sign + (resp. -) corresponds to $\bar{u} \in [-\pi, -\pi/2]$ (resp. $\bar{u} \in [-\pi/2, 0]$).

Since on a given characteristic only two points lie, \bar{P} and \tilde{P} , belonging to the same energy level, a jump from \bar{P} to \tilde{P} or vice-versa may happen only if one of these points is "in" while the other is "out". This occurs iff the function $X_H^{rel}(g)$, $g(q, p) = 0$ being the equation of $\mathcal{L}(S_1)$, takes opposite signs at points \bar{P} , \tilde{P} , and we go to analyse when such is the case.

It follows from (11) that for lagrangian (16)

$$(33) \quad X_H^{rel} = v_1 \frac{\partial}{\partial q_1} + v_2 \frac{\partial}{\partial q_2} + \frac{L_r}{r} (q_1 \frac{\partial}{\partial p_1} + q_2 \frac{\partial}{\partial p_2})$$

Below we work with the local chart (r, ϕ, y, α) , $y = (p_1^2 + p_2^2) / m^2 c^2$, $\alpha = \arctan \frac{p_2}{p_1}$, on $T^*(M)$. In terms of these coordinates the Legendre map (20) is given as follows:

$$(34) \quad y = \psi(r, x) \quad , \quad \alpha = \theta \quad ,$$

with $\psi(r, x) = \frac{4}{m^2 c^4} x L_x^2(r, x)$, and the expression (33) takes the form

$$(35) \quad X_H^{rel} = c\sqrt{x} \left(\cos u \frac{\partial}{\partial r} + \frac{\sin u}{r} \frac{\partial}{\partial \phi} \right) + \frac{\sqrt{\psi}}{mc} L_r \left(2 \cos u \frac{\partial}{\partial y} - \frac{\sin u}{\psi} \frac{\partial}{\partial \alpha} \right) \quad ,$$

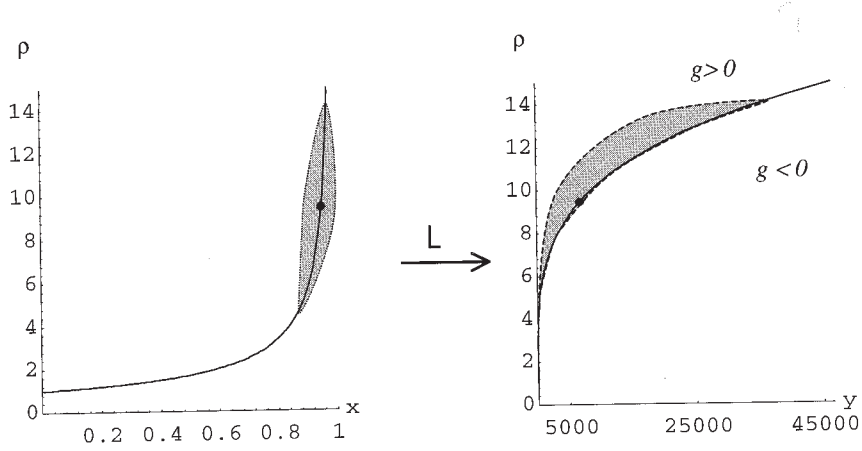
FIGURE 6. Legendre map for the oscillator ($*$ = r/r_0)

Due to (34)₁ hypersurface $\mathcal{L}(S_1)$ is given by:

$$g(r, y) = 0 \quad ,$$

with

$$(36) \quad g(r, y) = \frac{4}{m^2 c^4} x_1(r) \tilde{L}_x^2(r) - y \quad ,$$

where $x = x_1(r)$ is the function implicitly defined by equation $E_x(r, x) = 0$, and $\tilde{L}_x(r) = L_x(r, x_1(r))$. For the oscillator (14) the Legendre mapping \mathcal{L} is illustrated in Fig 6. In this case, as it is easy to see from (34) and (36), the image with respect to \mathcal{L} of a sufficiently small neighbourhood of a point $(q, v) \in S_1$ is contained in the region $\{g > 0\}$.

From (35) we get:

$$X_H^{rel}(g) = \cos u \left(c\sqrt{x}g_r + \frac{2\sqrt{\psi}}{mc} L_r g_y \right)$$

But from (21), (36) and $\mathcal{L}(S_1)$'s equation follows:

$$g_r = \frac{4}{m^2 c^4} \left[x_1' \tilde{L}_x^2 + 2x_1 \tilde{L}_x \left(\tilde{L}_{xr} + x_1' \tilde{L}_{xx} \right) \right] = \\ \frac{4\tilde{L}_x}{m^2 c^4} \left(x_1' \tilde{E}_x + 2x_1 \tilde{L}_{xr} \right) = \frac{8}{m^2 c^4} x_1 \tilde{L}_x \tilde{L}_{xr}$$

where, as before, $\tilde{f}(r)$ means $f(r, x_1(r))$. Hence, we obtain:

$$(37) \quad X_H^{rel}(g) = \frac{4}{m^2 c^3} \sqrt{x} \cos u \left(2x_1 \tilde{L}_x \tilde{L}_{xr} - L_x L_r \right)$$

Since $2xL_{xr} - L_r = E_r$ the restriction of (37) to S_1 is:

$$(38) \quad \widetilde{X_H^{rel}}(g) = \frac{4}{m^2 c^3} \sqrt{x_1} \cos u \tilde{L}_x \tilde{E}_r$$

In the case of the oscillator we have $\tilde{L}_x < 0$, $\tilde{E}_r > 0$. Therefore (38) shows that $\widetilde{X_H^{rel}}(g)$ is:

- 1) positive in the region S_1^+ corresponding to $u \in [\pi/2, \pi] \cup [-\pi, -\pi/2]$;
- 2) negative in the region S_1^- corresponding to $u \in [-\pi/2, \pi/2]$;
- 3) null on the bidimensional surface $W = S_1 \cap \{u = \pm\pi/2\}$.

Hence, keeping in mind what was said above about the range of \mathcal{L} and applying the transition principle, we see that:

1) If $\bar{P} \in S_1^+$, then \bar{P} is an in-point, while \tilde{P} is an out-point. Therefore, if the phase point, starting from outside S_1 , reaches it at \tilde{P} , its trajectory can be prolonged starting from \bar{P} (jump from \tilde{P} to \bar{P}).

2) If $\bar{P} \in S_1^-$, then \bar{P} is an out-point, while \tilde{P} is an in-point. Therefore, if the phase point, starting from outside S_1 , reaches it at \bar{P} , its trajectory can be prolonged starting from \tilde{P} (jump from \bar{P} to \tilde{P}).

3) If $\bar{P} \in W$, i.e. if $\bar{u} = \pm\pi/2$, then $\bar{P} \equiv \tilde{P}$. In this case the jump becomes infinitesimal and its direction is indicated by the hamiltonian vector field. In fact $\mathcal{L}(W)$ is described in terms of coordinates (r, ϕ, y, α) by equations

$$\begin{aligned} g(r, y) &= 0 \\ \cos u &= 0 \end{aligned}$$

But it follows from (35) that on W

$$X_H^{rel}(\cos u) = -\frac{L_r}{mc\sqrt{\psi}} \sin u = \pm \frac{L_r}{mc\sqrt{\psi}} \quad ,$$

which is different from zero on S_1 . More precisely, it is positive for $u = \pi/2$ and negative for $u = -\pi/2$; in both cases X_H^{rel} is directed toward the region S_1^- in which singular trajectories end.

Finally note that, for the oscillator (14),

$$X_H^{rel}(p_i) = \frac{q_i}{r} L_r \neq 0 \quad \text{on } S_2 \setminus S_1$$

Since $\mathcal{L}(S_2)$ coincides with the null section of $T^*(M)$, this shows that X_H is transversal to $\mathcal{L}(S_2)$.

4.4. Phase trajectories of the oscillator. In this concluding subsection we will study phase trajectories of the oscillator outside S . It will be shown that their behaviour depends strongly on their position with respect to the singular surface. Trajectories arriving at S have discontinuities, described by the transition principle, and together with others form a perfectly self-consistent dynamical model.

In this subsection coordinates (r, x, u, ϕ) are used. Let, as before

$$Z_L = \dot{r} \frac{\partial}{\partial r} + \dot{\phi} \frac{\partial}{\partial \phi} + \dot{x} \frac{\partial}{\partial x} + \dot{u} \frac{\partial}{\partial u}$$

be the vector field on $T(M)$ corresponding to the lagrangian L . Since I, E are first integrals, then

$$Z_L(I) = Z_L(E) = 0 \quad ,$$

or, equivalently

$$\begin{pmatrix} I_r & I_x & I_u \\ E_r & E_x & 0 \end{pmatrix} \begin{pmatrix} \dot{r} \\ \dot{x} \\ \dot{u} \end{pmatrix} = \begin{pmatrix} 0 \\ 0 \\ 0 \end{pmatrix}$$

Therefore

$$(39) \quad \dot{r} = -kI_uE_x \quad , \quad \dot{x} = kI_uE_r \quad , \quad \dot{u} = k(I_rE_x - I_xE_r)$$

On the other hand

$$\dot{r} = \frac{d}{dt} \left(\sqrt{q_1^2 + q_2^2} \right) = \frac{q_1v_1 + q_2v_2}{r} = c\sqrt{x} \cos u$$

So that

$$(40) \quad k = -\frac{c\sqrt{x} \cos u}{E_x I_u} = -\frac{c\sqrt{x} \sin u}{I E_x} = -\frac{c^2}{2r L_x E_x}$$

Notice also the relation:

$$(41) \quad I_r E_x - I_x E_r = \frac{E_x}{c\sqrt{x}} \sin u (2xL_x + rL_r) \quad ,$$

which follows directly from (18), (21), (19), and the relation

$$\frac{\partial}{\partial x} (\sqrt{x} L_x) = \frac{E_x}{2\sqrt{x}}$$

This way one gets the first three Euler-Lagrange equations:

$$(42) \quad \begin{aligned} \dot{r} &= c\sqrt{x} \cos u \\ \dot{x} &= -c \frac{E_r}{E_x} \sqrt{x} \cos u \\ \dot{u} &= -\frac{c \sin u}{2r\sqrt{x} L_x} (2xL_x + rL_r) \quad , \end{aligned}$$

which form a closed subsystem of the whole system.

Denote by \tilde{Z}_L the projection of Z_L onto the (x, r, u) -space. Then, solutions of (42) are identified with trajectories of \tilde{Z}_L . Due to obvious symmetry with respect to the (x, r) -plane it is sufficient to consider those of them for which $u \in [0, \pi]$ (i.e. counterclockwise motions around the center of the elastic force).

The fourth Euler-Lagrange equation

$$(43) \quad \dot{\phi} = \frac{c\sqrt{x}}{r} \sin u$$

can be found directly from :

$$\tan \phi = \frac{q_2}{q_1} \quad ,$$

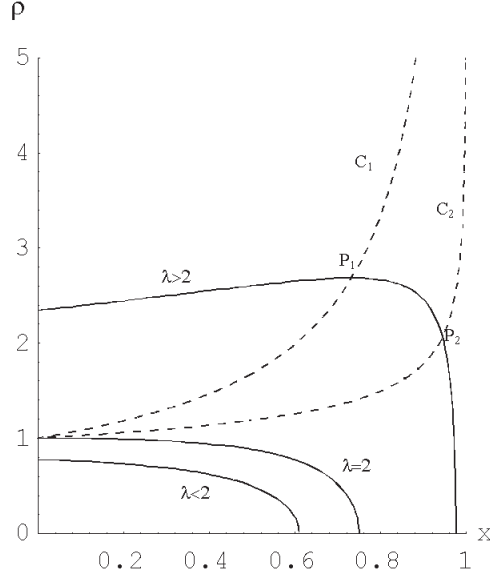

FIGURE 7. Energy level surfaces

so that

$$(44) \quad \phi(t) = c \int_0^t \frac{\sqrt{x(\tau)}}{r(\tau)} \sin u(\tau) d\tau + const. \quad ,$$

with $(x(t), r(t), u(t))$ being a solution of (42).

Let

$$(45) \quad \Xi_{\lambda, \mu} = \{E = \lambda mc^2\} \cap \{I = \mu mcr_0\}$$

Obviously,

$$\Xi_{\lambda, \mu} = \Gamma_{\lambda, \mu} \times S^1 \quad ,$$

where $\Gamma_{\lambda, \mu}$ is the projection of $\Xi_{\lambda, \mu}$ into (r, x, u) -space, while the circle S^1 corresponds to the cyclic coordinate ϕ . In their turn surfaces $\Xi_{\lambda, \mu}$ foliate the energy level 3-fold

$$\Sigma_\lambda = \{E = \lambda mc^2\}$$

In the case of oscillator (14) Σ_λ is not empty for $\lambda \in [1, +\infty]$.

Let $\tilde{\Sigma}_\lambda$ be the projection of Σ_λ onto the (r, x, u) -space. Obviously

$$\tilde{\Sigma}_\lambda = \Gamma_\lambda \times S^1 \quad ,$$

where Γ_λ is the curve in (r, x) -plane given by equation $E(r, x) = \lambda mc^2$ and S^1 is the circle corresponding to the cyclic coordinate u . Curves Γ_λ are shown in Fig 7. One can see that Γ_λ intersects the projections C_1, C_2 , of S_1, S_2 , respectively, as follows: i) at two different points P_1, P_2 , if $\lambda > 2$; ii) at the single point Q , if $\lambda = 2$; iii) nowhere, if $1 \leq \lambda < 2$. Therefore Σ_λ intersects S_1 and S_2 :

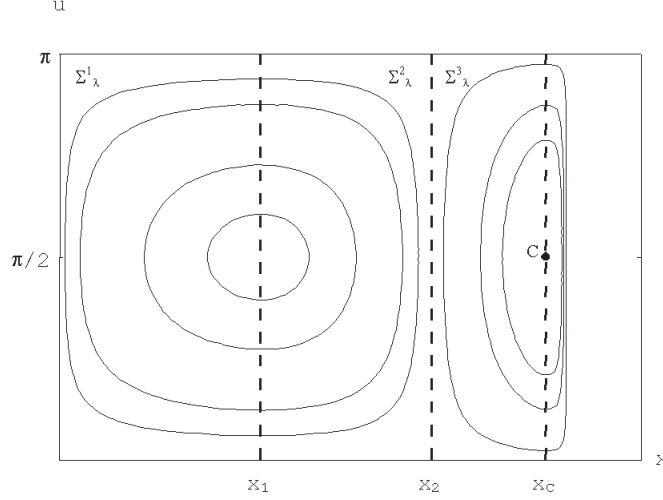

FIGURE 8. Phase portrait of the oscillator for a fixed value of the energy

1. along two tori $T_i = \Sigma_\lambda \cap S_i$, $i = 1, 2$, if $\lambda > 2$. These tori project onto P_i 's and have (ϕ, u) as cyclic coordinates.
2. along the circle $\gamma = S_1 \cap S_2$, with the cyclic coordinate ϕ , if $\lambda = 2$.
3. nowhere if $\lambda < 2$.

Therefore, $\Sigma_\lambda \setminus S$ has three connected components, if $\lambda > 2$ and is connected, if $\lambda \leq 2$.

In the case $\lambda > 2$ the behaviour of phase trajectories depends strongly on the connected component of $\Sigma_\lambda \setminus S$ they belong to. Due to (44) it is sufficient to study trajectories of (42), i.e. connected components of curves $\Gamma_{\lambda, \mu} \setminus \tilde{S}$, with \tilde{S} being the projection of S onto the (r, x, u) -space. In Fig. 8 the projections into the (x, u) -plane of three different kinds of such trajectories contained in $\tilde{\Sigma}_\lambda$ for a fixed λ are shown. As before we limit ourselves to $0 \leq u \leq \pi$. The three vertical lines correspond to the projections \tilde{T}_i of tori T_i 's (in fact they are circles, due to the cyclicity of coordinate u). Passing to further details, denote by $x_i = x_i(\lambda)$ the constant value of x along T_i . Connected components $\Sigma_\lambda^1, \Sigma_\lambda^2, \Sigma_\lambda^3$ of $\Sigma_\lambda \setminus S$ correspond to $x < x_1, x_1 < x < x_2$ and $x_2 < x$ respectively. The trajectories belonging to Σ_λ^1 and Σ_λ^2 are discontinuous in the sense that they end on S_1 and then jump, according to the transition principle, at another point of S_1 . More exactly, in the situation shown in the figure, such a trajectory starts from a point of $T_1^+ = T_1 \cap \{\pi/2 \leq u \leq \pi\}$ and reaches a point in $T_1^- = T_1 \cap \{0 \leq u \leq \pi/2\}$ in a finite time. Trajectories γ_1 and γ_2 , whose projections $\tilde{\gamma}_1$ and $\tilde{\gamma}_2$ are shown in Fig. 9, correspond to the same value of λ and of μ . Denote by $P_{start} \equiv (\bar{x}, \bar{r}, \pi - \bar{u}) \in \tilde{T}_1^+$ and $P_{end} \equiv (\bar{x}, \bar{r}, \bar{u}) \in \tilde{T}_1^-$ the common starting and ending points of $\tilde{\gamma}_1$ and $\tilde{\gamma}_2$. When a phase point starts from $(P_{start}, \phi_0) \equiv (\bar{x}, \bar{r}, \pi - \bar{u}, \phi_0)$

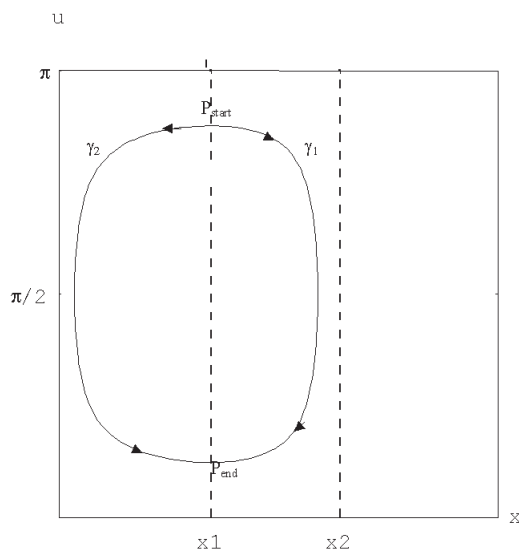

FIGURE 9. Jumping phase trajectories

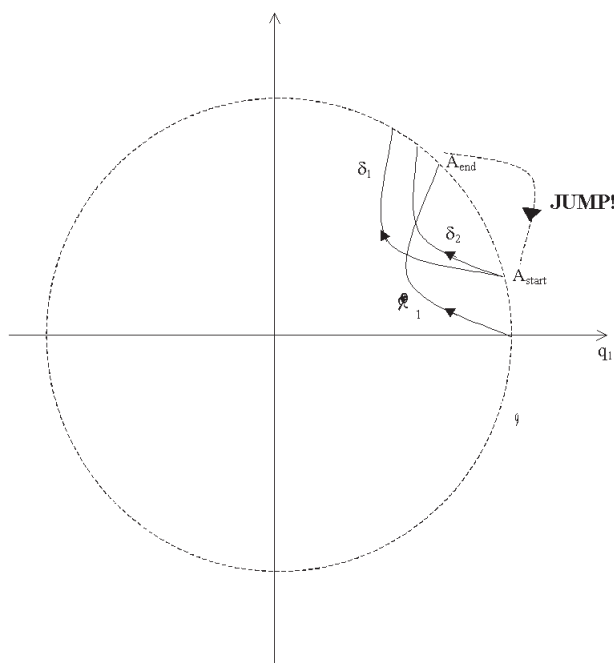

FIGURE 10. Jumping oscillator

and then goes along γ_1 (or, alternatively, γ_2) it arrives at the point $(P_{end}, \bar{\phi}) \equiv (\bar{x}, \bar{r}, \bar{u}, \bar{\phi})$ with $\bar{\phi}$ given by (31) and then proceeds along the trajectory whose projection is $\tilde{\gamma}_1$ or, alternatively, $\tilde{\gamma}_2$, and so on.

In Fig. 10 the situation in the configuration space $M = \{(q_1, q_2)\} = \{(r, \phi)\}$ is shown. The oscillating particle, starting from the point $(r = \bar{r}, \phi = 0)$, moves along the projection $\hat{\gamma}_1$ of γ_1 onto M until it

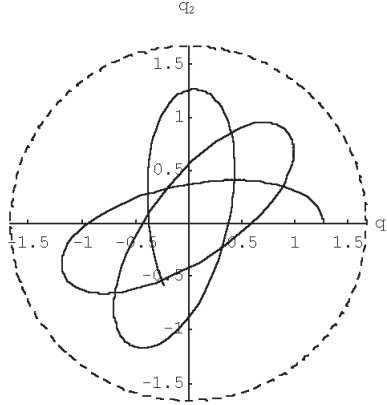

FIGURE 11. Regular precessions

reaches the point $A_{end} \equiv (r = \bar{r}, \phi = \bar{\phi})$. From there it jumps to the point $A_{start} \equiv (r = \bar{r}, \phi = \tilde{\phi})$, where $\tilde{\phi}$ is given by (31). Then it splits into the two trajectories δ_1, δ_2 , both with initial velocity

$$(x = \bar{x}, u = \tilde{u} = \pi - \bar{u}).$$

Consider now the trajectories of (42) contained in Σ_λ^3 . These are regular closed trajectories winding around the center $C = C(\lambda) \equiv (x = x_C, u = \pi/2)$, where $x_C = x_C(\lambda)$ is the zero of the equation $2xL_x(r_{en}(x, \lambda), x) + rL_r(r_{en}(x, \lambda), x) = 0$, and $r = r_{en}(x, \lambda)$ is implicitly defined by the equation $E(r, x) = \lambda mc^2$. The corresponding trajectories in the configuration space are shown in Fig. 11. They are precessions around the force center.

Note that both the discontinuous trajectories in Σ_λ^2 and the regular ones in Σ_λ^3 near S_2 tend to be parallel to it, so that this component of the singular hypersurface is never reached by the phase point, at least for trajectories with non-zero angular momentum.

Acknowledgments. The second author is obliged to Gaetano Vilasi for drawing his attention to not everywhere regular actions. His thanks go also to Igor Pavlotsky for a discussion of his recent results concerning Darwin's model.

REFERENCES

- [1] Dirac, P.M.A.: Forms of Relativistic Dynamics. Rev. Modern Physics **21**, 392-399 (1949)
- [2] Gelfand, I. M. ; Fomin, S.V.: Calculus of Variations. Englewood Cliffs (N.J.): Prentice-Hall 1963
- [3] Golubitsky, M. ; Guillemin, V.: Stable Mappings and Their Singularities. New York: Springer-Verlag 1973
- [4] Laserra, E. ; Pavlotsky, I.P. ; Strianese, M.: Classical electron radius as a consequence of Poincare group, preprint del D.I.I.M.A., Università di Salerno (1994)

- [5] Levi Civita, T.; Amaldi, U.: *Lezioni di Meccanica Razionale*, vol.2, tomo 2. Bologna: Zanichelli 1927
- [6] Modugno, M.; Vinogradov, A.M.: Some variations on the notion of connection. *Ann. Mat. Pura Appl.*, IV Ser. Vol. **CLXVII**, 33-71 (1994)
- [7] Pavlotsky, I.P.; Vilasi, G.: Some peculiar properties of the relativistic oscillator in the post-Galilean approximation, *Physica A* **214**, 68-81 (1995)
- [8] Vinogradov, A. M.; Kupershmidt, B.A.: The structures of hamiltonian mechanics. *Russ. Math. Surv.* **32:4**, 177-243 (1977)

DIPARTIMENTO DI MATEMATICA E INFORMATICA, UNIVERSITÀ DI SALERNO,
VIA S. ALLENDE, I-84081 BARONISSI (SA), ITALY AND ISTITUTO NAZIONALE DI
FISICA NUCLEARE, SEZIONE DI NAPOLI-SALERNO

E-mail address: pugliese@matna2.dma.unina.it

THE DIFFIETY INSTITUTE, DIPARTIMENTO DI MATEMATICA E INFORMATICA,
UNIVERSITÀ DI SALERNO, VIA S. ALLENDE, I-84081 BARONISSI (SA), ITALY AND
ISTITUTO NAZIONALE DI FISICA NUCLEARE, SEZIONE DI NAPOLI-SALERNO

E-mail address: vinograd@ponza.dia.unisa.it